

Photoinduced Reactions of 4-Methyl-5,6-diaza-2,4-cyclohexadien-1-one: (I) *trans-syn* Cyclobutane Dimer, $C_{10}H_{12}N_4O_2 \cdot H_2O$, and (II) Cycloaddition Product with 2-Propenol, $C_8H_{12}N_2O_2$

BY ISABELLA L. KARLE

Laboratory for the Structure of Matter, Naval Research Laboratory, Washington DC 20375, USA

(Received 16 April 1981; accepted 13 October 1981)

Abstract. (I) (Dimer) $C_{10}H_{12}N_4O_2 \cdot H_2O$, monoclinic, $P2_1/c$, $a = 14.289$ (4), $b = 6.091$ (2), $c = 14.836$ (4) Å, $\beta = 120.74$ (3)°, $Z = 4$, $M_r = 238.26$, $V = 1109.2$ Å³, $D_x = 1.427$ g cm⁻³, $R = 8.0\%$ (with substitution and disorder) for 1475 data ($>1\sigma$). (II) (Addition product) $C_8H_{12}N_2O_2$, monoclinic, $P2_1/n$, $a = 7.776$ (6), $b = 11.911$ (6), $c = 9.232$ (6) Å, $\beta = 102.35$ (6)°, $Z = 4$, $M_r = 168.2$, $V = 835.3$ Å³, $D_x = 1.337$ g cm⁻³, $R = 6.4\%$ for 1046 data ($>1\sigma$). Exposure of 4-methyl-5,6-diaza-2,4-cyclohexadien-1-one in solution to ultraviolet radiation produces the *trans-syn* cyclobutane-type dimer (I). The cyclobutane-type addition product (II) formed either by additional radiation of (I) or by reaction of 4-methyl-5,6-diaza-2,4-cyclohexadien-1-one with 2-propenol under the influence of ultraviolet light has the $-CH_2OH$ moiety *trans* and *anti* to the ketone moiety. Crystals of (I) contain about 13% of (II), disordered among two sites. Product (II) substitutes for (I) at random in the lattice.

Introduction. The induction of structural defects in DNA by irradiation with ultraviolet light or γ -rays has spurred substantial interest in the photochemistry not only of pyrimidine bases (Wang, 1976) but also of a variety of azacyclohexenes (see *e.g.* Kanaoka, Hasebe & Hatanaka, 1979). In the present paper crystal-structure analyses established the stereochemistry of two photoinduced products, (I) and (II), from 4-methyl-5,6-diaza-2,4-cyclohexadien-1-one. Contrary to the production of *cis-syn* cyclobutyl dimers as the most prevalent products from the irradiation of natural bases, irradiation of unnatural analogues such as 1,3,3-trimethyl-2,4(1*H*,3*H*)-pyridinedione and its 6-methyl analogue (Karle, 1982) as well as the 4-methyl-5,6-diaza-2,4-cyclohexadien-1-one, in the present case, has yielded the *trans-syn* cyclobutyl dimers. Further irradiation of (I) yields (II) which is identical to the product obtained by the cycloaddition of the starting material with 2-propenol under the influence of ultraviolet light (Kanaoka, Hasebe & Sato, 1980; Hasebe, 1980). Although a number of stereoisomers are

possible theoretically, (II) seems to be the principal product. The reaction mechanism in proceeding from (I) to (II) is obscure at present.

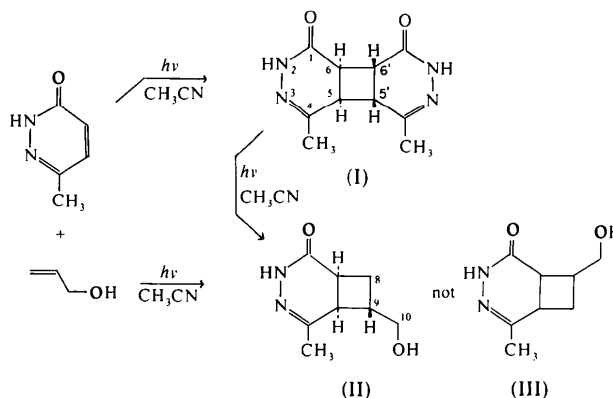

Crystals were provided by Y. Kanaoka, Hokkaido University. Diffraction data were collected from a clear, colorless prism of (I) and from a broken, jagged fragment of (II). Each crystal had good optical extinctions. The $\theta/2\theta$ scanning mode was used on a Nicolet P3F diffractometer with a graphite monochromator and data were collected to $2\theta_{\max} = 112^\circ$ with Cu $K\alpha$ radiation ($\lambda = 1.54178$ Å). The data were corrected for Lorentz and polarization effects but not for absorption. Each structure was solved by direct phase determination using the symbolic addition procedure. In structure (II), the 12 strongest peaks in a difference map corresponded to all the H atoms. Structure (II) was refined using all 1096 data by anisotropic full-matrix least-squares refinement on the heavy atoms while the approximate parameters for the H atoms were held fixed.

Although the 14 H positions could be readily identified in a difference map for structure (I), the four strongest peaks in the difference map did not correspond to any of the H positions. Furthermore, the anisotropic refinement which included the H-atom parameters would not produce an R factor below 11.0%. Originally the data had been measured on a Picker diffractometer. In order to ascertain that the

four extraneous peaks were not due to instrumental artifacts or to a dynamic process in the crystal, the data collection was repeated two more times, once on the same crystal using a Nicolet P3F diffractometer, and finally, one year later, on a different crystal from the original sample. The three sets of data were essentially indistinguishable, each producing four peaks somewhat heavier than the H atoms in a difference map calculated on the basis of the heavy atoms shown in Fig. 1 plus an H₂O molecule. They formed a four-membered ring that intersected the cyclobutane ring of the dimer at right angles.

A satisfactory explanation for the occurrence of the extraneous peaks in crystal (I) was not immediately apparent. Finally, a difference map calculated from a model that included the approximately refined coordinates of the dimer, the water molecule, the 14 H atoms and the four extraneous peaks at an occupancy near

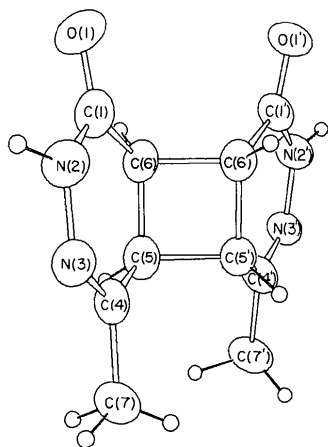

Fig. 1. Computer drawing of the *trans-syn* photodimer of 4-methyl-5,6-diaza-2,4-cyclohexadien-1-one. The thermal ellipsoids are represented at the 50% level.

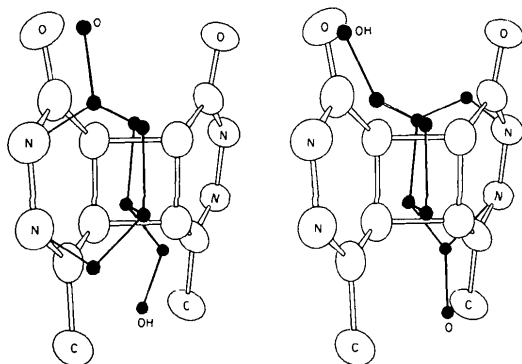

Fig. 2. The placement of two orientations of compound (II) (represented by the small dark circles), a minor component in the crystal of dimer (I), as compared to the atomic positions of (I). The position of the four-membered ring of (II) is common to both orientations of (II). The positions of the N atoms in both orientations of (II) coincide with the N atoms of (I).

13% showed a number of weak peaks, about $\frac{1}{3}$ to $\frac{1}{2}$ the weight of an H atom, in the vicinity of the atomic positions of the dimer. The problem could be resolved satisfactorily by considering a randomly mixed crystal where the minor component is compound (II), a product obtained from further irradiation of (I). Furthermore, if (II) were disordered among two sites, with the four-membered ring common to both, and the N-atom positions in the disordered, minor component common with the N-atom positions of the major component, as illustrated in the two diagrams in Fig. 2, the weights of the extraneous peaks in the difference maps would be quite compatible. Refinement on the positions and anisotropic thermal parameters of the C, N and O atoms of the major component while holding constant the positions of the 14 H atoms and the positions of the disordered minor component (with occupancies of 0.065, except 0.13 where overlapped), decreased the *R* factor from 11% to 8.0%. The values for the parameters of the major component changed by less than one e.s.d. Further trials with different occupancies and/or thermal factors of the minor components were not pursued.

Coordinates and B_{eq} values for the dimer (I) and addition product (II) are listed in Tables 1 and 2.* Bond lengths for both molecules are listed in Table 3.

* Lists of structure factors, anisotropic thermal parameters, approximate coordinates for H atoms, bond angles and torsional angles have been deposited with the British Library Lending Division as Supplementary Publication No. SUP 36473 (20 pp.). Copies may be obtained through The Executive Secretary, International Union of Crystallography, 5 Abbey Square, Chester CH1 2HU, England.

Table 1. Fractional coordinates and B_{eq} values for the *trans-syn* photodimer of 4-methyl-5,6-diaza-2,4-cyclohexadien-1-one

The e.s.d.'s for *x*, *y* and *z* are 0.0003, 0.0007 and 0.0003 respectively. The e.s.d.'s for B_{eq} are less than 0.01 Å². $B_{eq} = \frac{1}{3} \sum_i \sum_j \beta_{ij} a_i \cdot a_j$.

	<i>x</i>	<i>y</i>	<i>z</i>	B_{eq} (Å ²)
C(1)	0.6013	0.6833	0.4672	5.2
O(1)	0.5785	0.7424	0.5337	6.6
N(2)	0.5732	0.4801	0.4254	4.4
N(3)	0.5896	0.3897	0.3471	3.9
C(4)	0.6356	0.5051	0.3100	3.8
C(5)	0.6687	0.7421	0.3369	3.3
C(6)	0.6599	0.8289	0.4305	3.2
C(7)	0.6495	0.4086	0.2256	4.8
C(1')	0.8418	1.0181	0.5641	4.4
O(1')	0.8537	1.0557	0.6514	5.2
N(2')	0.8822	1.1564	0.5225	4.0
N(3')	0.8777	1.1335	0.4257	3.6
C(4')	0.8357	0.9629	0.3718	4.2
C(5')	0.7969	0.7700	0.4048	3.1
C(6')	0.7876	0.8110	0.5038	3.1
C(7')	0.8320	0.9440	0.2678	4.9
W	0.9930	0.4532	0.3724	4.6

Table 2. Fractional coordinates and B_{eq} values for the cycloaddition product of 4-methyl-5,6-diaza-2,4-cyclohexadien-1-one and 2-propenol

The e.s.d.'s for x , y and z are 0.0003, 0.0002 and 0.0003 respectively for atoms O(1)–C(6), and 0.0004, 0.0003 and 0.0004 respectively for atoms C(7)–C(10). The e.s.d.'s for B_{eq} are near 0.1 \AA^2 . $B_{eq} = \frac{4}{3} \sum_i \sum_j \beta_{ij} \mathbf{a}_i \cdot \mathbf{a}_j$.

	x	y	z	$B_{eq} (\text{\AA}^2)$
O(1)	-0.0111	0.3484	0.4832	4.7
O(2)	0.7476	0.1853	0.3523	5.6
C(1)	0.1173	0.3614	0.4248	3.7
N(2)	0.1741	0.4643	0.4040	4.2
N(3)	0.3132	0.4950	0.3365	4.0
C(4)	0.4036	0.4166	0.2951	3.6
C(5)	0.3743	0.2940	0.3142	3.3
C(6)	0.2091	0.2633	0.3747	3.8
C(7)	0.5510	0.4500	0.2229	5.2
C(8)	0.3299	0.2009	0.5070	4.9
C(9)	0.4965	0.2405	0.4537	3.7
C(10)	0.6140	0.1460	0.4229	4.4

Table 3. Bond lengths (\AA)

E.s.d.'s, based on the least-squares fit, are 0.006 \AA for the dimer and 0.004 \AA for the addition compound.

	Dimer		Addition compound
	unprimed	primed	
C(1)–O(1)	1.240	1.239	1.242
C(1)–N(2)	1.350	1.337	1.330
N(2)–N(3)	1.408	1.411	1.408
N(3)–C(4)	1.264	1.260	1.275
C(4)–C(5)	1.508	1.486	1.495
C(5)–C(6)	1.551	1.560	1.551
C(6)–C(1)	1.500	1.511	1.493
C(4)–C(7)	1.486	1.521	1.497
C(5)–C(5')	1.585		
C(6)–C(6')	1.580		
C(5)–C(9)			1.563
C(6)–C(8)			1.560
C(8)–C(9)			1.554
C(9)–C(10)			1.515
C(10)–O(2)			1.419

Discussion. Dimer (I), shown in Fig. 1, has the *trans-syn* cyclobutane-type configuration. Although the molecule lies in a general position in the unit cell, a pseudo twofold rotation axis that passes near the mid-points of the C(5)–C(5') bond and the C(6)–C(6') bond relates one half of the molecule to the other half. The averages of the coordinates of the pairs of atoms related by the pseudo rotation axis lie within 0.031 \AA of this pseudo symmetry axis. The bond lengths, Table 3, and bond angles are quite similar for the two halves of the molecule, in fact, within one or two standard deviations, except for the C(4)–C(7) and C(4')–C(7') pair. Bond lengths greater than 1.54 \AA in the cyclobutane ring commonly occur in the photo-induced dimers of pyrimidine bases (Karle, 1976, and references therein) and dimers of pyridinediones (Karle,

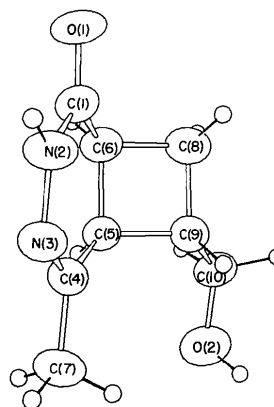

Fig. 3. Computer drawing of the photoaddition compound formed between 4-methyl-5,6-diaza-2,4-cyclohexadien-1-one and 2-propenol. The thermal ellipsoids are represented at the 50% level.

1982). Each of the three rings is planar within $\pm 0.10 \text{ \AA}$ with dihedral angles of 64 and 66° between the six-membered rings and the cyclobutyl ring. The dihedral angle measuring the fold in the cyclobutyl ring is 164°.

The crystal-structure analysis of the second crystal has established that the cyclobutane compound formed by the addition of 4-methyl-5,6-diaza-2,4-cyclohexadien-1-one and 2-propenol, see Fig. 3, has the hydroxyl group *anti* with respect to the carbonyl moiety as in (II), rather than *syn* as in (III). The stereochemistry at the three asymmetric centers C(5), C(6) and C(9) is shown to be the same as in dimer (I). Furthermore, the values for the bond lengths (Table 3), bond angles and torsional angles in comparable segments of molecules (I) and (II) are very close. The dihedral angle, 65°, between the planes of the six-membered ring and four-membered ring, is the same as the values found in dimer (I).

The crystal packing in both crystals is dominated by a network of hydrogen bonds (see Table 4). In each crystal there are pairs of $\text{NH}\cdots\text{O}=\text{C}$ bonds around centers of symmetry, a motif commonly found in crystals of pyrimidines (Karle, 1976 and references therein). In addition, in dimer (I) a water molecule crystallized near $x = 0$ participates in three hydrogen bonds, as a donor to O(1') and N(3') and an acceptor from N(2'). The hydrogen bonding around the water molecule is approximately trigonal and planar. When the minor component in the orientation, shown on the left in Fig. 2, substitutes occasionally for the dimer molecule, the hydrogen bonding involving O(1) and N(2) is the same as for O(1) and N(2) of the dimer while the OH group is a donor to O(1) of the molecule at $x, \frac{1}{2} - y, -\frac{1}{2} + z$. On the other hand, when the other orientation of the major component occurs in the cell, N(2) and N(3) make hydrogen bonds to the water molecule, similar to N(2') and N(3') of the dimer, and

Table 4. *Hydrogen bonds*E.s.d.'s for *D*...*A* are 0.004 Å.

	Donor	Acceptor	<i>D</i> ... <i>A</i>	<i>D</i> -H	H... <i>A</i>	<i>DH</i> ... <i>A</i>	Symmetry of <i>A</i>
Dimer (I)	N(2)	O(1)	2.872 Å	1.00 Å	1.91 Å	159°	1 - <i>x</i> , 1 - <i>y</i> , 1 - <i>z</i>
	N(2')	<i>W</i>	2.903	0.99	1.91	175	2 - <i>x</i> , 2 - <i>y</i> , 1 - <i>z</i>
	<i>W</i>	O(1')	2.836	0.92	1.95	162	<i>x</i> , 2 - <i>y</i> , -½ + <i>z</i>
	<i>W</i>	N(3')	2.909	0.92	1.99	172	<i>x</i> , -1 + <i>y</i> , <i>z</i>
Addition compound (II)	N(2)	O(1)	2.869	0.99	1.88	177	<i>x</i> , 1 - <i>y</i> , 1 - <i>z</i>
	O(2)	O(1)	2.791	1.12	1.73	157	1 + <i>x</i> , <i>y</i> , <i>z</i>

the OH group can make a hydrogen bond with N(2) of the dimer.

References

HASEBE, M. (1980). PhD Thesis, Hokkaido Univ.
 KANAOKA, Y., HASEBE, M. & HATANAKA, Y. (1979). *Heterocycles*, **13**, 263-266.

KANAOKA, Y., HASEBE, M. & SATO, E. (1980). *Heterocycles*, **14**, 114.

KARLE, I. L. (1976). *Photochemistry and Photobiology of Nucleic Acids*, Vol. 1, edited by S. Y. WANG, pp. 483-519. New York: Academic Press.

KARLE, I. L. (1982). *Acta Cryst.* **B38**, 1016-1018.

WANG, S. Y. (1976). *Photochemistry and Photobiology of Nucleic Acids*, Vol. 1. New York: Academic Press.

Acta Cryst. (1982). **B38**, 1022-1024

The Tricyclic Photorearrangement Product from the Addition of 3-Methyl-5,6-diaza-2,4-cyclohexadien-1-one to 2-Propenol, 7-Hydroxymethyl-8-methyl-2,3-diazatricyclo[3.3.0.0^{2,8}]octan-4-one, C₈H₁₂N₂O₂

BY ISABELLA L. KARLE

Laboratory for the Structure of Matter, Naval Research Laboratory, Washington DC 20375, USA

(Received 16 April 1981; accepted 12 October 1981)

Abstract. C₈H₁₂N₂O₂, triclinic, *P* $\bar{1}$, *a* = 6.953 (4), *b* = 7.811 (8), *c* = 8.328 (7) Å, α = 94.34 (7), β = 91.43 (6), γ = 115.29 (6)°, *V* = 407.0 Å³, *Z* = 2, *M_r* = 168.2, m.p. = 413 K (decomp.), *D_x* = 1.372 g cm⁻³, *R* = 6.4% for 1039 independent reflections measured to 2θ = 112°. Irradiation of a solution containing 3-methyl-5,6-diaza-2,4-cyclohexadien-1-one and 2-propenol produces a cyclobutane addition compound which, upon further irradiation, opens and switches bonds to form a tricyclic molecule. Crystal-structure analysis has established that the molecule contains one three-membered ring and two five-membered rings.

Introduction. The irradiation by ultraviolet light of a solution containing 4-methyl-5,6-diaza-2,4-cyclohexadien-1-one and 2-propenol leads to a cyclobutane-type addition product with the hydroxyl group *anti* with respect to the carbonyl O (Karle, 1982; Kanaoka, Hasebe & Sato, 1980; Hasebe, 1980). The same procedure with the isomeric 3-methyl-5,6-diaza-2,4-cyclohexadien-1-one (I) leads to a cyclobutane addition

product (II) and then proceeds further to yield a rearrangement product. The objective of the crystal-structure analysis presented in this paper was to elucidate the structural formula, and stereochemistry, of the rearrangement product which has been shown to be (III).

